

STUDED BANDED OTTOMAN



18"Ø G29 Off-White Napa Leather With Shiny Brass Studs

Twelve pentagon shaped leather panels are sewn together and stitched with parallel banding and finished with equally spaced metal studs for our round Studded Banded Ottoman. The hand-moulded fill adds structure and stability to the sculptural form creating comfortable seating with a soft presence with refined statement detail. The Studded Banded Ottoman is finished with a laced detail closure.

ITEM NO. IOT1805

MATERIALS Leather

FILL Foam

LEATHER OPTIONS Shasta, Napa

STUD FINISH OPTIONS Natural Brass, Antique Brass, Matte Black, Matte Nickel, Plated Nickel

DIMENSIONS + WEIGHTS

14" Ø 15 · 20 lbs

18" Ø 32 · 37 lbs

22" Ø 40 · 45 lbs

CUSTOMIZATIONS Dimensions, alternative leathers, colors and materials upon request. A physical swatch is required for all COM/COL. Additional fees may apply.

NAPA LEATHER

NAPA is a full-grain leather featuring a durable protective finish with a small pebble grain



SHASTA LEATHER

SHASTA is a full-aniline leather featuring an unprotected finish that patinas and gains natural character with use

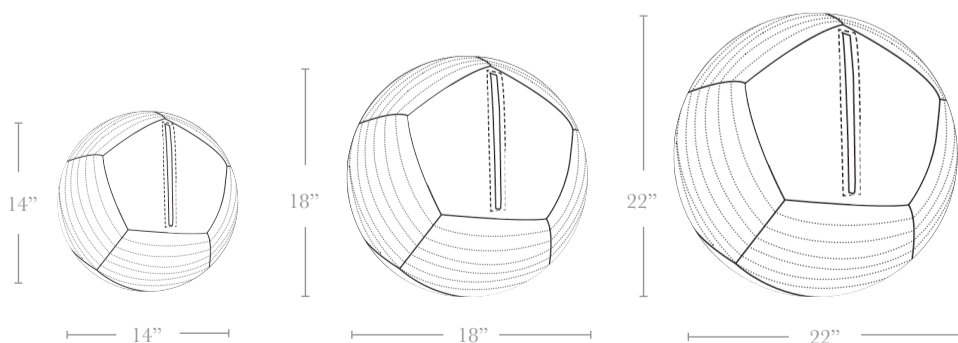

All items are made by hand to order in Long Island, NY. Dimensions are approximate. Our products are made of organic materials and therefore subject to natural variances. Differences in the color or texture of leather and signs of wear are inherent. Small scratches or blemishes found within the product are naturally occurring.